



Acquisitions Fireplaces Ltd. Acquisitions House, 24-26 Holmes Road, London **NW5 3AB**

Tel: 020 7482 2949 **Fax:** 020 7267 4361 **e-mail:** sales@acquisitions.co.uk

www.acquisitions.co.uk

Manufactured for Acquisitions by Esse Engineering Ltd

ACQUISITIONS

OF LONDON



Bloomsbury

GAS FIRED STOVE



INSTALLATION & USER INSTRUCTIONS
(TO BE LEFT WITH THE CUSTOMER)

UK & IRELAND



CONTENTS

Technical Information	Page 2	Commissioning the Stove	Page 6
Important Notes	Page 3	Check for Spillage	Page 12
Dimensions & Clearances	Page 3	Customer Briefings	Page 12
Installation	Page 4	Servicing Instructions	Page 13
Positioning the coals	Page 5	Customer Information Section	Pages 14-19

TECHNICAL INFORMATION

GAS	NATURAL GAS	PROPANE
CATEGORY	I ₂ H	I ₃ P
HEAT INPUT (GROSS)	6.98kW	6.5kW
SUPPLY PRESSURE	20mbar	37mbar
INJECTOR SIZE	440	190
SETTING PRESSURE	16.4mbar HIGH 2.3mbar LOW	32.5mbar HIGH 5.0mbar LOW
GAS CONNECTION	8mm O.D. Tube	8mm O.D. Tube
GAS CONSUMPTION	0.67m ³ /h	0.24m ³ /h

IMPORTANT NOTES

This stove is a fuel effect radiant convector. Before installation, ensure that the local distribution conditions (identification of the type of gas and pressure) and the adjustment of the appliance are compatible. The data label is located at the rear of the stove. The installation must be in accordance with these Instructions and National Regulations and must be carried out by a qualified installer.

Any flue damper plate or flue restrictor must be removed or fixed permanently in a fully open position, or shall only be fitted in accordance with National Regulations.

If the chimney has previously been used to burn solid fuel, the chimney should be swept before the stove is installed.

Before the stove is installed a flue test in accordance with National Regulations should be carried out. The gas connection must be in accordance with National Regulations.

The stove is fitted with a spillage monitoring system consisting of a thermal switch connected to a thermocouple interrupter. This system is not adjustable, and must not be put out of action. If any parts of the spillage monitoring system require replacement only original manufacturer's parts must be used.

All surfaces except the control knob are considered to be working surfaces.

DIMENSIONS AND CLEARANCES

Fig. 1 - Dimensions

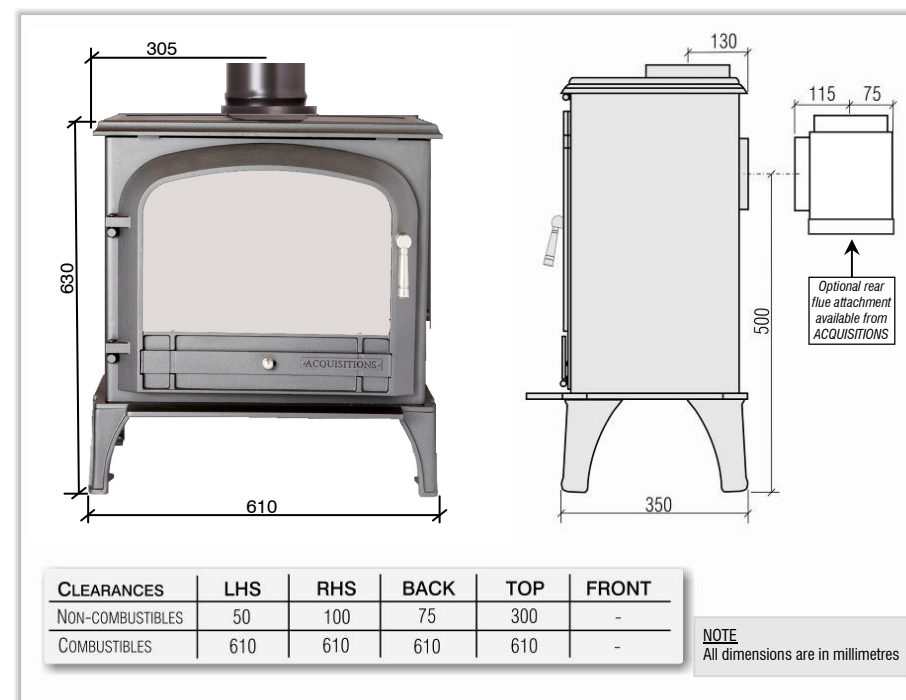

INSTALLATION

Install the stove in accordance with the requirements given below. If a concealed gas connection is to be made prepare the pipe work prior to installing the stove.

Positioning the Stove

The stove can be installed in any adequate area suitable for multi-fuel fires and stoves. Clearances for non-combustible material in the fireplace opening must be at least 50mm on the left hand side, 100mm on the right hand side and 75mm at the back. These distances must be extended to a minimum clearance of 610mm from any combustible material.

Hearth

The stove must stand on a fireproof hearth made of non-combustible material of minimum thickness 12mm and be of sufficient size to accommodate the stove (see Fig. 1).

Fire Surround & Shelves

It is recommended that a fire surround should not be closer than 610mm from the stove, if manufactured from a combustible material.

Flue Connection

The flue should be at least 3m high and at least 125mm diameter or equivalent area. Horizontal or negative gradients in the flue pipe should be avoided.

It is recommended that a minimum height of 610mm from the stove should be established before any significant change in the direction of the flue.

An optional rear flue attachment is available as an accessory from the manufacturer (see Fig. 1)

Ventilation

Ventilation should be in accordance with National Regulations. In the United Kingdom purpose provided ventilation is not normally required.

Gas Connection

The gas supply connection is at the right hand side of the stove on the gas valve.

A nut and olive (strapped to the valve body), tail pipe and a pressure test elbow are supplied with the stove for easy connection.

The gas supply should incorporate a service tap, be purged and any loose material removed.

Connect the gas supply pipe and check for gas soundness.

POSITIONING THE COALS

If fitted, remove the screw securing the door handle and open the stove door.

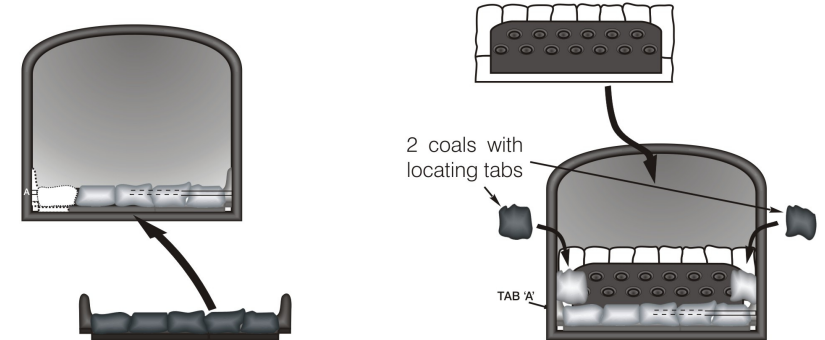

Position the front coal piece under the flame strip and in front of tab-'A', ensure that the pilot hole and flame strip are not obstructed.

Position the back board onto the burner tray ensuring it is correctly seated behind Tab 'A' and that the flame strip is not obstructed. Locate 2 coals with locating tabs on either end of back board.

PLACE THE COALS AS RANDOMLY AS POSSIBLE FOR THE BEST FLAME EFFECT

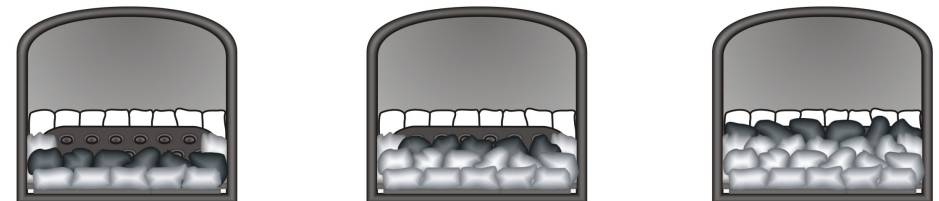

ROW 1
(6 COALS)

ROW 2
(5 COALS)

ROW 3
(6 COALS)

Lay the seventeen coals supplied as shown

- ⚠ DO NOT add any extra coal.
- ⚠ DO NOT force coals down between the spacers on the backboard, or between the back board and front coal piece.

Close the stove door. Replace the door securing screw if fitted.

Under no circumstances should the stove be operated with the door open, without the door attached or the glass in the door damaged.

COMMISSIONING THE STOVE

Manually Operated Stoves

The stove is fitted with a pilot light, piezo spark and flame sensing device.

The control knob is located behind the right-hand foot of the stove.

The pilot light is centrally located behind the front coal piece.

Should the stove be extinguished for any reason wait 3 minutes before re-ignition is attempted.

Connect a suitable pressure gauge to the pressure test point.

Lighting the Pilot

Depress control knob fully. Whilst depressed turn knob slowly through 90° anti-clockwise to **PILOT** setting. A click will be heard and the piezo spark should light the pilot. Repeat until pilot is visibly lit. If necessary, the operation of the spark can be viewed by temporarily opening the front door.

Keep knob depressed at this point for 10-15 seconds and release the knob. The pilot light will remain lit.

Low Setting

If the Pilot light is not already lit, light the pilot as described above.

With the control knob at **PILOT** setting, depress and turn anti-clockwise to **LOW** setting and release the knob.

High Setting

If the stove is not already lit on **LOW** setting, ignite stove to **LOW** setting as described above.

Turn the control knob anti-clockwise until **HIGH** setting is reached. Check that the supply pressure and/or setting pressure is in accordance with that given in the TECHNICAL INFORMATION section.

Turning the Stove OFF

From any heat setting, depress control knob fully and turn clockwise to **PILOT** position.

Disconnect the pressure gauge, replace the test point sealing screw and test for gas soundness.

Turning the Pilot OFF

From any heat setting or the **PILOT** position, depress control knob fully and turn clockwise to **OFF** position.

Fig 4 - Control Knob (Manual)

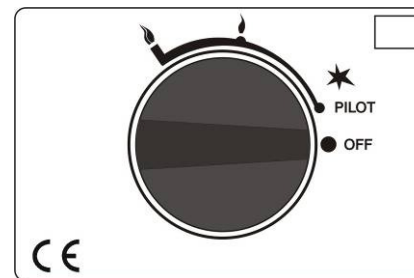

Remote Controlled Stoves

This stove has a pilot that must be lit manually. When lighting the pilot, follow these instructions exactly.

LIGHTING INSTRUCTIONS (refer to Fig. 5)

Should the stove be extinguished for any reason wait 3 minutes before ignition is attempted. Slacken the left hand pressure test sealing screw on the gas valve (Fig. 5) and connect a suitable pressure gauge.



Knob A cannot be turned from 'PILOT' to 'OFF' unless it is pushed in slightly. Do not force.

NOTE

Lighting the Pilot

Turn Knob A (Fig. 5) anti-clockwise towards the ignition position (**IGN**) until reaching stop, press down and hold for five seconds (only pilot gas flows).

Continue pressing down Knob A while turning further anti-clockwise to activate piezo; continue to hold down for 10 seconds after pilot burner has been lit. If pilot does not light, steps 1 and 2 can be repeated immediately.

Upon lighting, release knob and turn further anti-clockwise to **ON** position. Pilot gas flows and main gas flows in accordance to the temperature setting knob B.

High Setting

If the pilot is not already lit, light the pilot as described above.

Turn knob B anti-clockwise until the high setting is reached. Check the setting pressure is in accordance with that given in the TECHNICAL INFORMATION section (page 2). Adjust if necessary (Fig. 5).

Low Setting

Turn Knob B clockwise to low setting (just before flame is extinguished). Check that the setting pressure is in accordance with that given in the TECHNICAL INFORMATION section (page 2). Adjust if necessary (Fig. 5).

Fig. 5 - Remote Controlled Valve

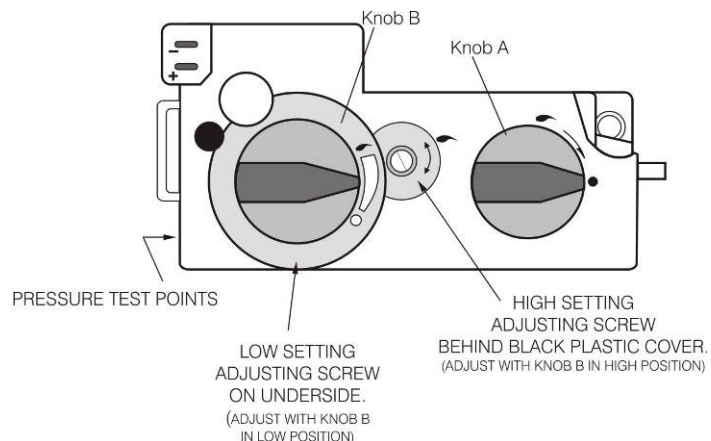

Adjusting the Flame Height

- To turn the fire on and/or to increase flame height, press **ON** button of the remote handset. Continue pressing until the desired flame height is obtained. Press and hold the **OFF** button to reverse the procedure.
- The receiver is equipped with a built-in delay, recognisable by the flickering light, to facilitate fine adjustment of the flame.
- The motorised valve is equipped with a slip clutch, allowing manual adjustment of main gas by turning Knob B.
- Set the desired programme and temperature on the handset as described in the **HANDSET OPERATION** section (page 9)

To Turn OFF Gas to Stove

- Turn Knob A clockwise until reaching stop. In this position only pilot gas flows. To shut off the valve completely, press down slightly and continue to turn clockwise from **PILOT** position to the **OFF** position.
- The safety interlock prevents re-ignition of the pilot flame until the thermocouple has cooled down sufficiently (elapsed time will vary based on the thermocouple type). Switching off the remote is not necessary. Disconnect the pressure gauge, tighten the test point sealing screw and test for gas soundness.

HANDSET OPERATION (refer to Fig. 6)



NOTE

Mains electrical power is not required as this system runs on batteries only.

Battery information:

Handset – 1 x 9V block

Receiver – 4 x 1.5V AA

Setting the Display

- After connecting the battery or by simultaneously pressing **AUTO** and **TIMER**, the display flashes. You are in set mode.
- From set mode, press **AUTO** to switch from °F (and 12-hour clock) to °C (and 24-hour clock) or vice versa.
- The display will automatically return to manual after some time, but you may immediately return to manual by re-pressing the **TIMER** button.

Setting the Current Time

- After connecting the battery or by simultaneously pressing **AUTO** and **TIMER**, the display flashes. You are in set mode.
- From set mode, press (▲) to set the hour and (▼) to set the minute.
- Wait or press **TIMER** to return to 'manual' mode.

Programming the Desired Set Temperature

- Press **AUTO** until the display flashes.
- Press (▲) or (▼) to set desired temperature.
- Wait or press **AUTO** to switch to automatic mode.
- A sensor in the transmitter measures the room temperature. The controller compares the room temperature with the set temperature and sends a signal to the receiver to turn the gas valve motor, which adjusts the flame height accordingly.

Fig. 6 - Remote Transmitter



Programming the Timer

- Press **TIMER** until **P1*** flashes (period 1, heating cycle on).
- Set the time for the beginning of the first heating period by pressing (**▲**) for hour and (**▼**) for minute.
- Press **TIMER** again; **P1D** appears.
- Set the time for end of the first heating period.
- Press **TIMER** again to set the second heating period **P2D** (heat off).
- Store both heating periods by pressing **TIMER** again.
- If only one heating period is desired, programme the same time for **P2*** and **P2D** as for **P1*** and **P1D**.

Manual Mode (MAN in display) for Manual Flame Height Adjustment

- Press (**▲**) to turn on the fire (main burner) or to increase flame height.
- Press (**▼**) to decrease flame or to turn down to pilot.
- To incrementally increase or decrease the flame height, lightly tap either the (**▲**) or (**▼**) button.
- The 'send' symbol appears in the upper left corner of the display when either large button is depressed.
- The LED of the receiver flashes when Knob B of the valve reaches the end stops.

Automatic Mode (Auto in display) for Temperature Control

- Briefly press **AUTO**. The set temperature will appear briefly before the display reverts to the room temperature.

Timer Mode (Timer in Display)

- During heating periods **P1*** and **P2*** the temperature is controlled in the same manner as in automatic mode.
- When the timer programme turns to **D** (heating cycle off), the motor will then valve to pilot and there is no temperature control. This minimises battery consumption.
- You may press **AUTO** to verify the set temperature and then press **TIMER** to return to timer mode.
- You may press either the (**▲**) or (**▼**) button from any mode for manual override.
- To prolong battery life, we recommend switching the transmitter to manual mode and turning the fire to pilot with the (**▼**) button before turning the appliance off. If the transmitter is left in automatic or timer mode, the batteries will continue to be used when the appliance is off.

Changing the Battery

- If **BATT** appears in upper right hand corner of the display or if the LED of the receiver becomes faint, please change the battery from transmitter or receiver. If the batteries lose power, the flame height can be adjusted by manually turning Knob B (see Fig. 7).



NOTE

Please note, the placement of the transmitter (temperature sensor) is important to assure proper temperature regulation. Generally, a more constant temperature will be assured, if the transmitter is not too far from the gas appliance. Before switching to **AUTO** or **TIMER** Mode, press either button (**▲**) or (**▼**) to verify the reception (when the send symbol appears in the transmitter display, the receiver's LED must illuminate). For the **AUTO** or **TIMER** mode to function correctly, the transmitter must remain within range of the receiver. The transmitter should not be used in very close proximity to the receiver (less than 1m/3ft) as this could block the motor when the knob reaches the end points of its turning radius. The knob must then be turned manually to free the blockage.

The temperature is controlled by activating the motor for a specific length of time to adjust the appropriate flame height. This time is calculated by the transmitter and depends on variables such as room size, heater capacity, battery power etc.

Therefore, a few cycles are necessary before an optimum is achieved. If a low flame is sufficient to provide enough warmth to the room, then the appliance will cycle between low fire and off.

This allows longer periods with the flame on and provides a more uniform room temperature.

Fig. 7 - Covers with Connectors for Micro Switch and Motor.

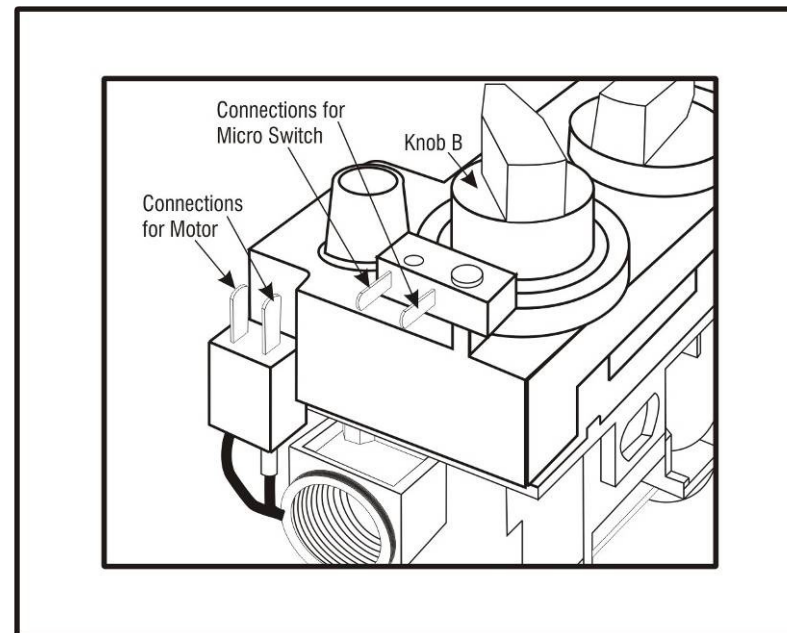
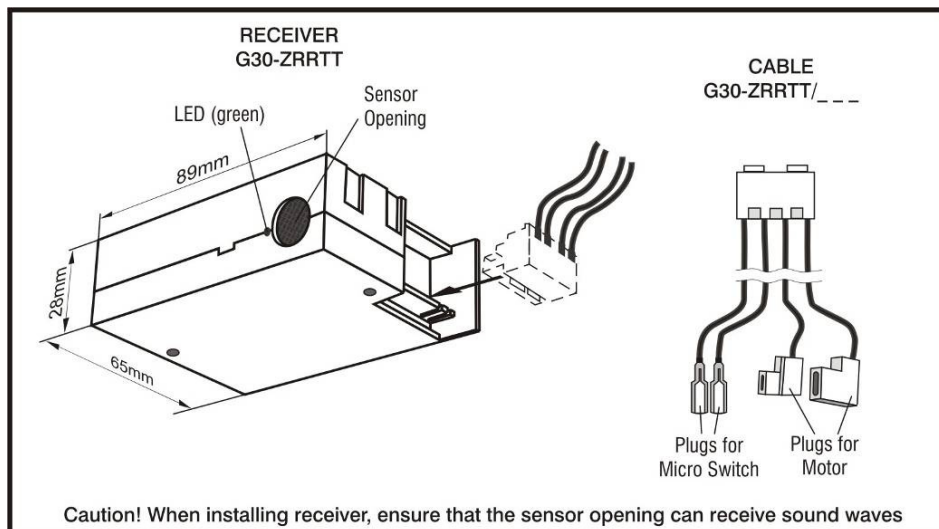

Fig. 8 - Components with the Remote Package



CHECK FOR SPILLAGE

Close all doors and windows in the room containing the appliance. Light the stove and turn the control knob to 'HIGH', leave the appliance for 5 minutes.

Apply a smoke match along the bottom edge of the draught diverter. The installation is satisfactory if the smoke is drawn into the stove. If in doubt wait a further 10 minutes and then repeat the test.

If there is a nearby room the spillage test should be repeated with the fan running and all connecting doors between the stove and the fan left open.

If in doubt disconnect the appliance and seek expert advice.

CUSTOMER BRIEFINGS

Hand these instructions and the Users Instructions to the customer.

Advise the customer how to use the stove.

Point out that the Operating procedure is in the Users Instructions.

Explain to the customer that the stove has a flame failure and spillage monitoring system.

Point out the explanation of this system in the Users Instructions.

Advise that if the monitoring system repeatedly shuts off the stove, it should be switched off and a specialist consulted.

Advise that if the fire goes out for any reason, wait at least 3 minutes before re-lighting.

Advise the customer that the stove should not be used at a lower setting than the 'LOW' position.

Advise the customer that due to newness of materials the stove may give off a slight smell for a period of time after commissioning. This is quite normal and any odours should disperse after a few hours operation.

Stress that no extra coals or logs must be added over and above those supplied with the stove and that any replacement parts must only be authorised ACQUISITIONS spares.

Recommend that the stove is regularly serviced and the flue system checked by qualified persons.

SERVICING INSTRUCTIONS

The stove is fitted with a spillage monitoring system consisting of a thermal switch connected to a thermocouple interrupter. This system is not adjustable and must not be put out of action. If any parts of the spillage monitoring system require replacement only original manufacturers' parts must be used.

The thermal switch rating is 120°C. Quote this rating if ordering a new switch.

1. The following servicing procedure should be carried out regularly and only by a qualified person. Ensure that the fire is turned off and is cold.
2. Remove the coals, back board and front coal piece in the reverse order to that described in POSITIONING THE COALS section (page 5).
3. Remove any deposits of dirt, lint etc. carefully from the burner flame strip, tray, and pilot assembly with a soft brush.
4. Remove the pilot lint arrester and clean with a soft brush if necessary. Replace the pilot lint arrester.
5. Due to the intense temperatures reached in the fire, some surface cracks may appear on the ceramic components. This is quite normal and will not affect the safe operation of the fire. Replace the front coal piece, back board and coals as described in the POSITIONING THE COALS section (page 5).
6. Close the stove door; replace the screw securing the door handle or door.
7. Check the supply pressure as described in the COMMISSIONING THE STOVE section (page 6).
8. Ensure correct operation of the flue as described in CHECK FOR SPILLAGE section (page 12).

CUSTOMER INFORMATION SECTION

This stove has been individually designed to add charm and character to your home. Providing a highly efficient heat source, the stove has the look and charm of a real stove coupled with the convenience of clean burning gas. Due to newness of materials the stove may give off a slight smell for a period of time after commissioning. This is quite normal and any odours should disperse after a few hours operation.

The installation must be in accordance with National Regulations and must be carried out by a qualified installer.



Under no circumstances should the stove be operated with the door open, without the door attached or the glass in the door damaged.

WARNING

All surfaces except the controls are considered to be working surfaces. Most parts of the stove will get hot during and after use. If young children, the elderly, or infirm are likely to be near the stove a suitable fireguard is recommended.

A combustible shelf may be fitted over the appliance provided that in the case of a 150mm or less deep shelf there is at least 610mm clearance above the top of the stove.

The stove should not be used for any other purpose than as a room heater and decorative stove.

Hearth - The stove must stand on a non-combustible hearth of at least 12mm thickness, and be of sufficient size to accommodate the stove.

Ventilation - Ventilation should be in accordance with National Regulations. In the United Kingdom purpose provided ventilation is not normally required.

Fire Surrounds - It is recommended that a fire surround made from combustible material should not be closer than 610mm to the stove.

Coal Arrangement - The coal should only be arranged as shown in the coal layout given on page 5 by a qualified person.

The stove must only be fitted with the ceramics supplied. **DO NOT** use any extra logs or coal.

OPERATING THE STOVE

MANUALLY OPERATED STOVES

The stove is fitted with a pilot light, piezo spark and flame sensing device.

The control knob is located behind the right hand foot of the stove.

The pilot light is located centrally behind the front coal piece.

Should the stove be extinguished for any reason wait 3 minutes before re-ignition is attempted.

The stove should not be used at a lower setting than the **LOW** position.

Fig. 9 - Control Knob

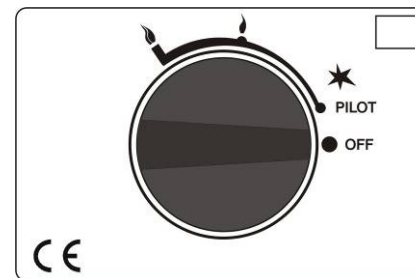

Lighting the Pilot

Depress control knob fully. Whilst depressed turn knob slowly through 90° anti-clockwise to **PILOT** setting

A click will be heard and the piezo spark should light the pilot. Repeat until pilot is visibly lit. If necessary, the operation of the spark can be viewed by temporarily opening the front door.

Keep knob depressed at this point for 10-15 seconds and release the knob. The pilot light will remain lit.

Low setting

If the pilot is not already lit, light the pilot as described above.

With control knob at **PILOT** setting, depress and turn anti-clockwise to **LOW** setting and release the knob.

High Setting

If the stove is already lit on **LOW** setting, ignite stove to **LOW** setting as described above.

Turn the control knob progressively in an anti-clockwise direction until the desired level is achieved, up to the **HIGH** setting.

Turning the Stove OFF

From any heat setting, depress control knob fully and turn clockwise to **PILOT** position.

Turning the Pilot OFF

From any heat setting or the **PILOT** position, depress the control knob fully and turn clockwise to **OFF** position.

REMOTE CONTROLLED STOVES

This stove has a pilot that must be lit manually. When lighting the pilot, follow these instructions exactly.

Lighting Instructions (refer to Fig. 10)



Knob A cannot be turned from 'PILOT' to 'OFF' unless it is pushed in slightly. Do not force.

NOTE

Lighting the Pilot

1. Turn Knob A (Fig. 10) anti-clockwise towards the ignition position (**IGN**) until reaching stop, press down and hold for five seconds (only pilot gas flows).
2. Continue pressing down Knob A while turning further anti-clockwise to activate piezo, continue to hold down for 10 seconds after pilot burner has been lit. If pilot does not light, steps 1 and 2 can be repeated immediately.
3. Upon lighting, release knob and turn further anti-clockwise to **ON** position. Pilot gas flows and main gas flows in accordance to the temperature setting Knob B.

Fig. 10 - Remote Controlled Valve.

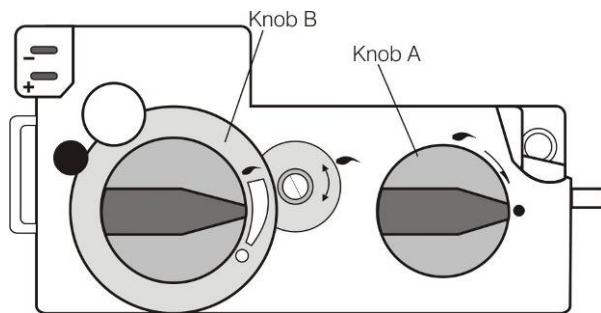

Adjusting the Flame Height

- To turn the fire on and/or to increase flame height, press **ON** button of the remote handset. Continue pressing until the desired flame height is obtained. Press and hold the **OFF** button to reverse the procedure.
- The receiver is equipped with a built-in delay, recognisable by the flickering light, to facilitate fine adjustment of the flame.
- The motorised valve is equipped with a slip clutch, allowing manual adjustment of main gas by turning Knob B.
- Set the desired programme and temperature on the handset as described in the Handset Operation section (page 17).

To Turn OFF Gas to Stove

- Turn Knob A clockwise until reaching stop. In this position only pilot gas flows. To shut off the valve completely, press down slightly and continue to turn clockwise from pilot position to the OFF position.
- The safety interlock prevents re-ignition of the pilot flame until the thermocouple has cooled down sufficiently (elapsed time will vary based on thermocouple type). Switching off the remote is not necessary.

Handset Operation (refer to Fig. 11)



Mains electrical power is not required as this system runs on batteries only.

Battery information:

Handset - 1 x 9V block

NOTE Receiver - 4 x 1.5V AA

Setting the Display

- After connecting the battery or by simultaneously pressing **AUTO** and **TIMER**, the display flashes. You are in set mode.
- From set mode, press **AUTO** to switch from °F (and 12-hour clock) to °C (and 24 hour clock) or vice versa.
- The display will automatically return to manual after some time, but you may immediately return to manual by pressing the **TIMER** button.

Setting the Current Time

- After connecting the battery or by simultaneously pressing **AUTO** and **TIMER**, the display flashes. You are in set mode.
- From set mode press (▲) to set hour and (▼) to set minute.
- Wait or press **TIMER** to return to **MANUAL** mode.

Programming the Desired Set Temperature

- Press **AUTO** until the display flashes.
- Press (▲) or (▼) to set the desired temperature.
- Wait or press **AUTO** to switch to automatic mode.
- A sensor in the transmitter measures the room temperature. The controller compares the room temperature with the set temperature and sends a signal to the receiver to turn the gas valve motor, which adjusts the flame height accordingly.

Fig. 11 - Remote Transmitter



Programming the Timer

- Press **TIMER** until **P1*** flashes (period 1, heating cycle on).
- Set the time for the beginning of the first heating period by pressing (**▲**) for hour and (**▼**) for minute.
- Press **TIMER** again; and **P1▶** appears.
- Set the timer for end of the first heating period.
- Press **TIMER** again to set the second heating period **P2▶** (heat off).
- Store both heating periods by pressing **TIMER** again.
- If only one heating period is desired, program the same time for **P2*** and **P2▶** as for **P1*** and **P1▶**.

Manual Mode (MAN in display) for Manual Flame Height Adjustment

- Press (**▲**) to turn on the fire (main burner) or to increase flame height.
- Press (**▼**) to decrease flame or to turn down to pilot.
- To incrementally increase or decrease the flame height, lightly tap either the (**▲**) or (**▼**) button.
- The **send** symbol appears in the upper left corner of the display when either large button is depressed.
- The LED of the receiver flashes when knob B of the valve reaches the end stops.

Automatic Mode (Auto in display) for Temperature Control

- Briefly press **AUTO**. The set temperature will appear briefly before the display reverts to the room temperature.

Timer Mode (Timer in Display)

- During heating periods **P1*** and **P2*** the temperature is controlled in the same manner as in automatic mode.
- When the timer program turns to **▶** (heating cycle off), the motor will then valve to pilot and there is no temperature control. This minimises battery consumption.
- You may press **AUTO** to verify the set temperature and then press **TIMER** to return to timer mode.
- You may press either the (**▲**) or (**▼**) button from any mode for manual override.
- To prolong battery life, we recommend switching the transmitter to manual mode and turning the fire to pilot with the (**▼**) button before turning the appliance off. If the transmitter is left in automatic or timer mode, the batteries will continue to be used when the appliance is off.

Changing the Battery

- If **BATT** appears in upper right hand corner of the display or if the LED of the receiver becomes faint, please change the battery from transmitter or receiver. If the batteries lose power, the flame height can be adjusted by manually turning Knob B.



NOTE

Please note, the placement of the transmitter (temperature sensor) is important to assure proper temperature regulation. Generally, a more constant temperature will be assured, if the transmitter is not too far from the gas appliance. Before switching to **AUTO** or **TIMER** Mode, press either button (**▲**) or (**▼**) to verify the reception (when the send symbol appears in the transmitter display, the receiver's LED must illuminate). For the **AUTO** or **TIMER** mode to function correctly, the transmitter must remain within range of the receiver. The transmitter should not be used in very close proximity to the receiver (less than 1m/3ft) as this could block the motor when the knob reaches the end points of its turning radius. The knob must then be turned manually to free the blockage.

The temperature is controlled by activating the motor for a specific length of time to adjust the appropriate flame height. The time is calculated by the transmitter and depends on variables such as room size, heater capacity, battery power, etc.

Therefore, a few cycles are necessary before optimum is achieved. If a low flame is sufficient to provide enough warmth to the room, then the appliance will cycle between low fire and off.

This allows longer periods with the flame on and provides a more uniform room temperature.



NOTE

It is recommended to turn the combination control either to the **OFF** or **PILOT** position if the appliance is left unattended for longer periods (i.e. away), so that it cannot receive commands from the remote transmitter. Exercise caution when leaving the appliance unattended, in exceptional cases sound waves from sources other than the transmitter can cause changes in flame height adjustment.

SPILLAGE MONITORING SYSTEM

The stove is fitted with a spillage monitoring system which senses any excess temperature due to a flue restriction or blockage. In this event the gas supply is automatically turned off. Should this occur turn the control knob to the **OFF** position and wait approximately 10 minutes for the switch to automatically reset. Re-light the stove as described in OPERATING THE STOVE section (page 15). If the stove repeatedly shuts itself off, **DO NOT** use the stove and have the flue system checked by a qualified person.

The spillage monitoring system is not adjustable and must not be put out of action

CLEANING

Ensure that the stove is turned off before cleaning and is cold.

DO NOT use abrasive cleaning agents.

The stove is supplied with ceramic coal that should only be cleaned and arranged by a qualified person in accordance with the Installation Instructions.

DATA INFORMATION

The Data Label is located at the rear of the stove.

SERVICING

It is essential that the stove is regularly serviced, and the flue system checked by a qualified person.